

SONY®



XCG Series

XCG-5005E

XCG-U100E

XCG-SX97E

XCG-V60E

www.sony.com/videocameras

Sony expands its XC digital camera lineup with the introduction of the high-quality XCG Series. The XCG Series incorporates the GigE Vision interface, which is specifically standardized for machine vision applications based on Gigabit Ethernet technology. In accordance with the growing demand for large-scale systems, this interface enables the cameras to transfer a large amount of data over long distances. The use of an Ethernet cable and availability of a wide variety of peripheral devices contribute to significant cost-cutting benefits when designing a complete vision system. Moreover, by incorporating a packet re-send mechanism, the XCG Series can securely transmit data to the host computer.

The XCG Series consists of four models – the XCG-5005E, the XCG-U100E, the XCG-SX97E, and the XCG-V60E. Each camera varies in resolution and frame rates, and offers unique benefits that users have come to expect from Sony’s camera products. These cameras retain some of the same functionality found in Sony’s renowned XCD Series such as bulk trigger mode, sequential trigger mode, and a partial scanning function. In addition, the XCG-SX97E and XCG-5005E cameras feature critical functions for security applications such as IR wavelength coverage (XCG-SX97E) and an ultra-high 5-megapixel resolution (XCG-5005E).

The XCG camera series offers choice, flexibility, and high image quality options to match your specific inspection application requirements. By utilizing the features and benefits of the GigE Vision interface, the XCG Series expands the possibilities for factory automation and security applications, while also delivering the potential of significant cost savings.

FEATURES

XCG-5005E, XCG-U100E, XCG-SX97E, XCG-V60E

With a variety of resolutions and feature-rich benefits, it’s never been easier to select the right camera for your specific factory automation, machine vision, and high-end security applications.

Please refer to table 1.

GigE Vision Interface

The adoption of the GigE Vision interface adds to the outstanding value and performance of the XCG camera series. Answering the growing demand for large-scale systems, the XCG Series can transfer large amounts of data over long distances (up to 100m). In addition, the cameras are reinforced with a packet re-send mechanism that can eliminate the loss of transferred data. Furthermore, the overall cost of a vision system can be reduced with these cameras thanks to the availability of a variety of peripheral devices.

Please refer to table 2.

Table 1 : Full Lineup

		XCG-5005E	XCG-U100E	XCG-SX97E	XCG-V60E
Sensor		Ultra-high Resolution	High Resolution	IR Sensitivity	High Speed
	Progressive Scan IT CCD	2/3-type	1/1.8-type	2/3-type	1/3-type
	Cell Size (H) x (V)	3.45 x 3.45 μm	4.4 x 4.4 μm	6.45 x 6.45 μm	7.4 x 7.4 μm
	Standard Picture Size (H) x (V)	2,448 x 2,048	1,600 x 1,200 (UXGA)	1,360 x 1,024 (SXGA)	640 x 480 (VGA)
	Frame Rate	15 fps	15 fps	16 fps	90 fps
Applications		High-end Security and Factory Automation	Factory Automation	High-end Security and Factory Automation	Factory Automation

Table 2 : Interface Comparison

Interfaces	GigE Vision	IEEE 1394b
Distance of Image Transfer	Up to 100 m	Up to 4.5 m
Bandwidth of Image Transfer	1000 Mbps	800 Mbps
Data Transfer	Packet Transfer	Packet Transfer
Configuration (Software)	GenlCam	IIDC
System Configuration	A Wide Range of Peripheral Devices	Inexpensive Peripheral Devices

Driver for the XCG Series

The XCG Series is equipped with a Sony-provided, dedicated driver. This image filter driver enables jumbo-packet data transfer across all industry-standard hardware. It is also capable of non-GigE Vision data transfer in GigE Vision environments.

Bulk Trigger Mode/Sequential Trigger Mode

In addition to its conventional trigger mode, the XCG Series features an advanced "Bulk Trigger Mode" and "Sequential Trigger Mode." "Bulk Trigger Mode" allows the XCG Series to capture up to 16 images in rapid succession using a single software or hardware trigger. "Sequential Trigger Mode" periodically sends a software or hardware trigger to the camera to capture the successive images. With the cameras' memory channel, up to 16 different settings can be called up to capture these images. Thanks to these beneficial trigger options, the XCG Series reduces the need to receive signals from the host PC.

High Resistance to Shock and Vibration

Due to their robustness and vibration resistance, the XCG Series cameras deliver outstanding performance in the most challenging environmental conditions.

Other features

- Vertical and Horizontal Partial Scanning
- Vertical Binning

DIMENSIONS

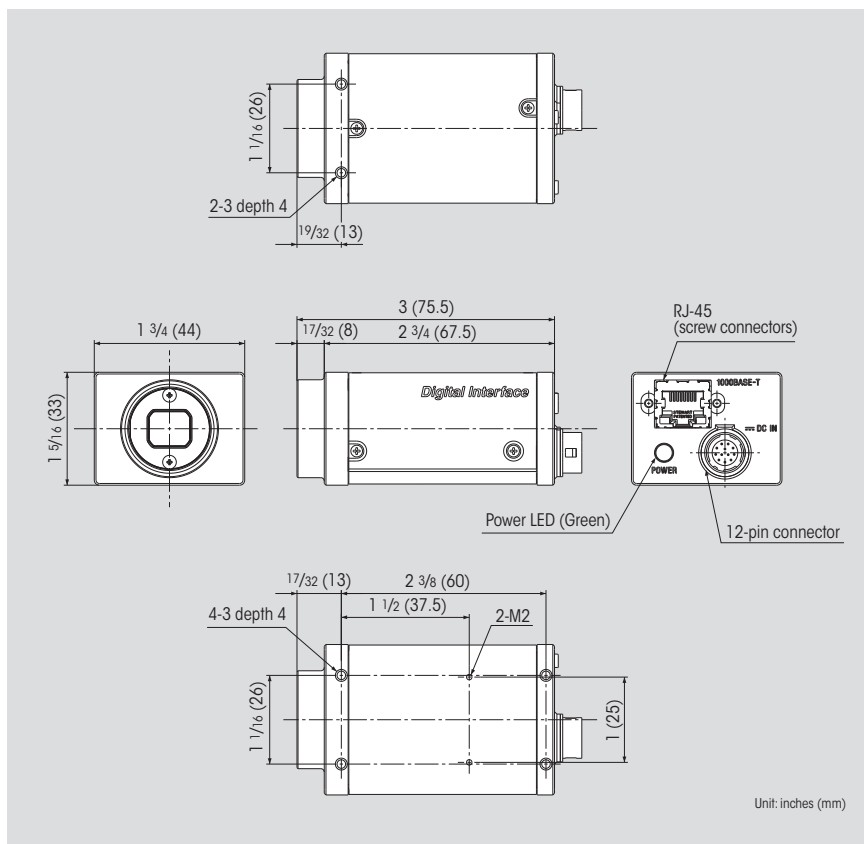

PIN ASSIGNMENT

12-pin connector

Pin No.	
1	DC IN (Ground)
2	DC IN
3	GND
4	Strobe/Exposure OUT
5	ISO OUT- (Isolated)
6	ISO OUT+ (Isolated)
7	ISO IN+ (Isolated)
8	GND
9	NC
10	NC
11	Trigger IN
12	ISO IN- (Isolated)

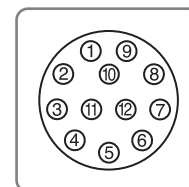

OPTIONAL ACCESSORIES



Tripod Adaptor
VCT-ST701



Camera Adaptors
DC-700

Cables
CCXC-12P02N
CCXC-12P05N
CCXC-12P10N

Specifications

	XCG-5005E	XCG-U100E	XCG-SX97E	XCG-V60E
Image device	2/3-type progressive scan IT CCD	1/1.8-type progressive scan IT CCD	2/3-type progressive scan IT CCD	1/3-type progressive scan IT CCD
Cell size (H x V)	3.45 x 3.45 μm	4.4 x 4.4 μm	6.45 x 6.45 μm	7.4 x 7.4 μm
Standard picture size (H x V)	2,448 x 2,048 pixels	1,600 x 1,200 pixels	1,360 x 1,024 pixels	640 x 480 pixels
Resolution depth	8/10/12 bits/pixel			
Lens mount	C mount			
Standard frame rate	15 fps	15 fps	16 fps	90 fps
Digital interface	1000BASE-T (GigE Vision compatible)			
Sensitivity	400 lx at F5.6 (0 dB)	400 lx at F5.6 (0 dB)	400 lx at F11 (0 dB)	400 lx at F5.6 (0 dB)
Minimum illumination	Less than 1 lx (Gain +18 dB, F1.4)	Less than 1 lx (Gain +18 dB, F1.4)	Less than 0.2 lx (Gain +18 dB, F1.4)	Less than 1 lx (Gain +18 dB, F1.4)
Gain control	Manual 0 to +18dB, Auto gain			
Readout mode	Normal/Binning/Partial scan			
Binning	Vertical (1x2)			
Partial scan	Vertical/Horizontal			
Shutter speed	2 to 1/100,000 s			
External trigger shutter	Pulse-edge detection mode, Pulse-width detection mode, Special trigger mode (Bulk trigger mode/Sequential trigger mode)			
Memory channel	16 channels			
Readout features	Binnarization, Gamma correction (LUT), Built-in test pattern			
Power requirements	DC+10.5 to +15.0 V			
Power consumption (Max.)	4.3 W	3.1 W	3.1 W	3.1 W
Dimensions	1 3/4 x 1 5/16 x 2 3/4 inches (44 x 33 x 67.5 mm)			
Weight	Less than 5 3/4 oz (145 g)			
Operating temperature	23 to 113 °F (-5 to 45 °C)			
Storage temperature	-22 to 140 °F (-30 to 60 °C)			
Operating humidity	20 to 80% (no condensation)			
Storage humidity	20 to 95% (no condensation)			
Vibration resistance	10 G (20 to 200Hz)			
Shock resistance	70 G			
Supplied accessories	Lens mount cap, Operating instructions			

SONY

Sony Electronics Inc.
1 Sony Drive
Park Ridge, NJ 07656
www.sony.com/videocameras

IS-1216 (MK10570V1)

© 2009 Sony Electronics Inc. All rights reserved.
Reproduction in whole or in part without written permission is prohibited.
Design, features, and specifications are subject to change without notice.
All non-metric weights and measurements are approximate.
Sony is a registered trademark of Sony Corporation.
All other trademarks are the properties of their respective owners.

Printed in USA (4/09)