

M1214-MP

12mm F1.4

for 2/3" format cameras

C-Mount

Model No.	M1214-MP		Effective	Front	f 21.0mm
Focal Length	12mm		Lens Aperture	Rear	f 13.0mm
Max. Aperture Ratio	1 : 1.4		Distortion	-0.35%(y=4.0)	
Max. Image Format	8.8 x 6.6mm (f11mm)		Back Focal Length	13.1mm	
Operation Range	Iris	F1.4 - 16C	Flange Back Length	17.526mm	
	Focus	0.3m - Inf.	Mount	C-Mount	
Control	Iris	Manual	Filter Size	M30.5 P=0.5mm	
	Focus	Manual	Dimensions	f33.5 x 28.2mm	
Object Dimension at M.O.D.	22.1 x 16.5cm		Weight	65g	
Angle of View	D	49.2°	1/2"	37.0°	
	H	40.4°		30.0°	
	V	30.8°		22.7°	
Operating Temperature	-20°C ~ +50°C				

2/3

C

M.O.D. : Minimum Object Distance

Dimensions

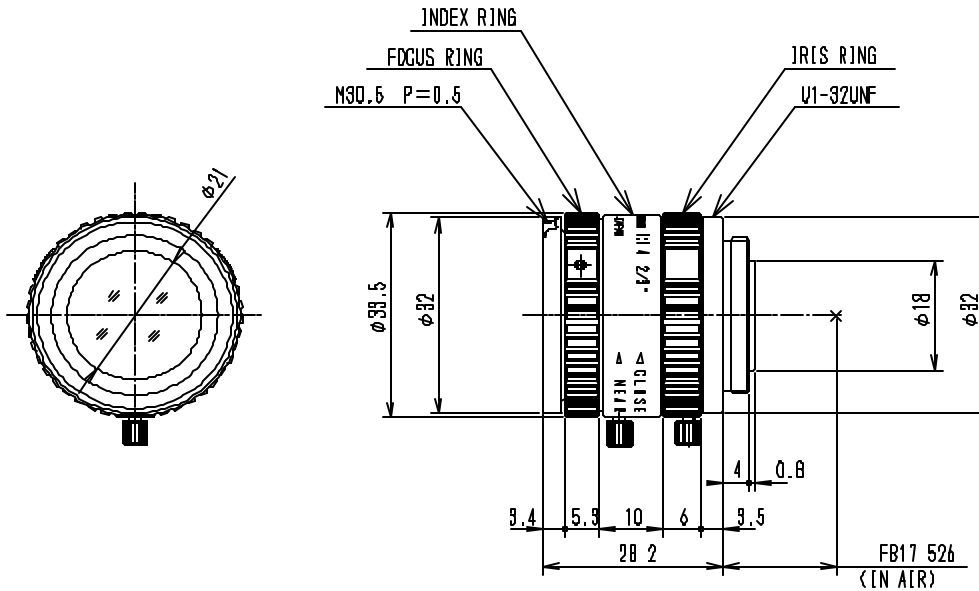

F